



1T DEEP RIPPER

The C&M Single Tyne Deep Ripper is designed to maximize cropping land and improve farming yield. Known for its heavy-duty build, it effectively breaks down tree roots and soil compaction in hard-to-reach areas such as around trees and roads.

Its compact design allows for close ripping, while its 3500kg weight ensures deep penetration up to 1150mm.

FEATURES & BENEFITS

- Up to 1150mm ripping depth
- Heavy-duty construction
- Hydraulic depth control
- Dual-plane drawbar connection
- Large floatation tyres
- Bisalloy grade 400 tyne
- High ground clearance



COLLIER & MILLER



**SCAN FOR
MORE INFO**

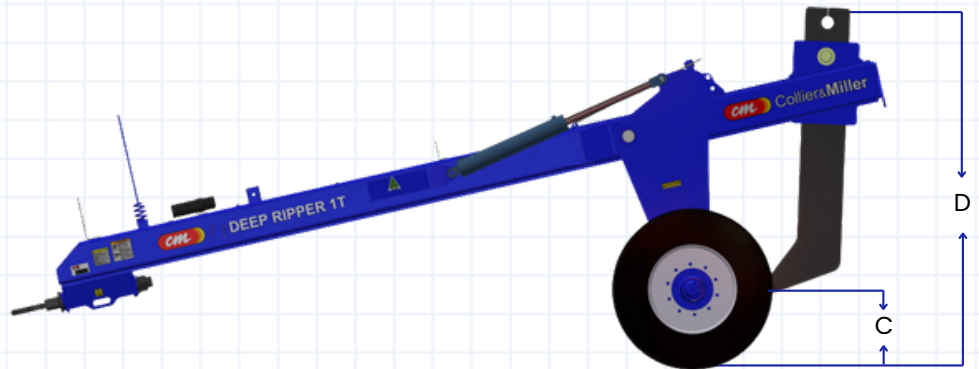
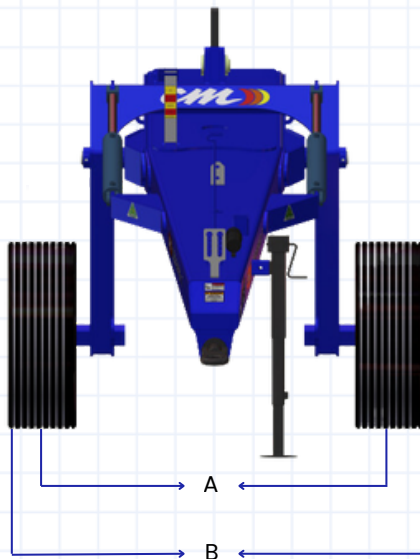
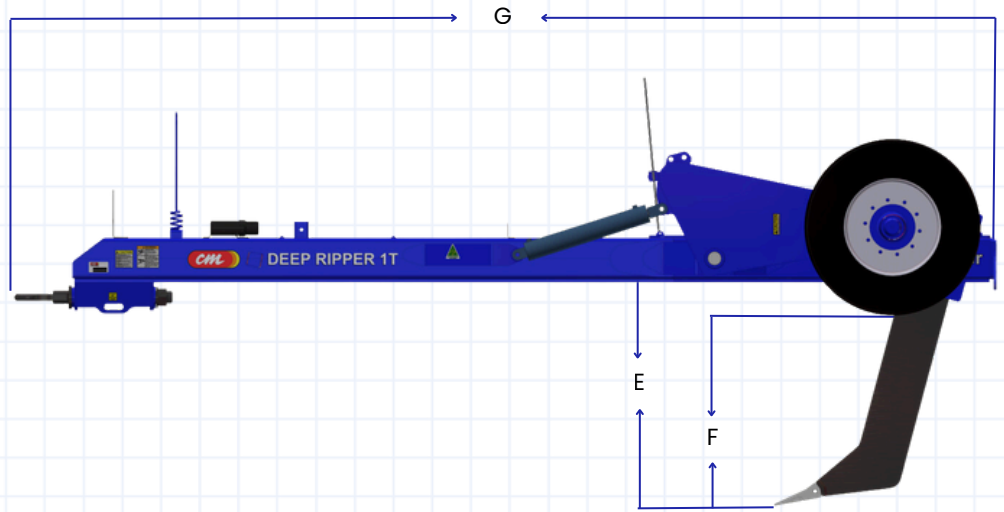

MODEL	CMTR
DESCRIPTION	Single Tyne Trailing Heavy Duty Deep Ripper
TYNE THICKNESS AND MATERIAL	50mm 400 Grade Bisalloy
NUMBER OF TYNES	1
AXLES	4500kgs each @ 25kph
TYRES	385/65 R 22.5
A= WHEEL CENTRES	1976mm
B= OVERALL WIDTH OF MACHINE	2365mm
C= TRAVELLING CLEARANCE FROM POINT TO GROUND	388mm
D= OVER ALL HEIGHT	2187mm
E= CLEARANCE UNDER BAR	1161mm
F= MACHINE RIPPING DEPTH	965mm
G= OVER ALL LENGTH	5962mm
MINIMUM HORSE POWER	350HP
WEIGHT	3500kg
DRAW BAR BUSH DIAMETER	51mm
POWDER COATED FINISH	Yes

COLLIER & MILLER